



## A Fast, Automatic Printer For Digital Type Data Devices

LAST year -hp- introduced a high-speed digital recorder\* which automatically printed the measurements made by -hp- frequency counters. The recorder was arranged to print numbers of up to 11 columns (digits) on adding machine tape at rates up to 5 complete print-outs per second and thus considerably increased the speed and ease with which frequency measurements could be recorded.

SEE ALSO:  
 Transistorized  
 power supply, p. 4

Introduction of this recorder for frequency counters uncovered a need for a print-out instrument with the same high speed, simplicity and reliability of mechanism, and low required signal power but one which would be capable of operating with other types of digital data devices. A second version of the recorder has therefore been designed to permit fast print-outs from other devices that gather data in digital form. Where the first recorder was de-

signed to operate from a staircase code, the second is designed to operate from 10-wire codes. It is thus especially valuable for use with digital voltmeters but can also be used with analog-digital converters, remote readout units, frequency counters with 10-wire outputs, shaft encoders, 10-lamp or 10-element systems, stepping switches, mechanical counters with commutators, relay and diode matrices, etc., to print digitized measurements of voltage, current, pressure, acceleration, flow, deflection and other quantities.

Although the new printer is arranged to operate with devices that provide their outputs in the form of 10-wire codes, this often includes devices that internally employ other codes, since such devices are generally usable with suitable output translators for readout pur-

\*Alan S. Bagley and Ed A. Hilton, *A Fast Digital Recorder with Analog Output for Automatic Data Plotting*, Hewlett-Packard Journal, Vol. 8, No. 7, March, 1957

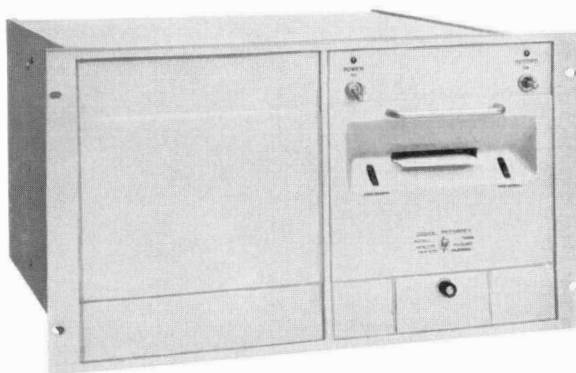

Fig. 1. -hp- Model 561A printer provides fast print-outs for digital data devices such as digital voltmeters, analog-digital converters, etc., that provide an output in 10-wire code form. Print-outs can be made of 11 columns at rates up to 5 lines per second.

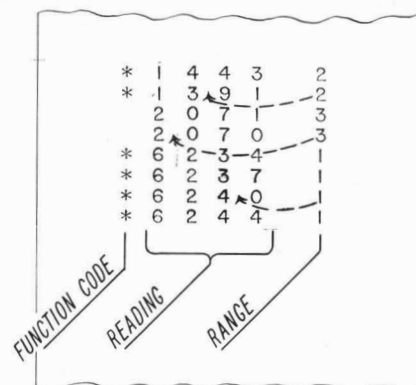

Fig. 2. Typical print-out obtainable when using printer with digital voltmeter. Left-hand column has been programmed to indicate source of reading, but if a mixture of + and - readings were to be obtained, this or another column could be used to identify reading polarity. Special symbols can also be provided. Print-outs are made on 3-inch adding machine tape.

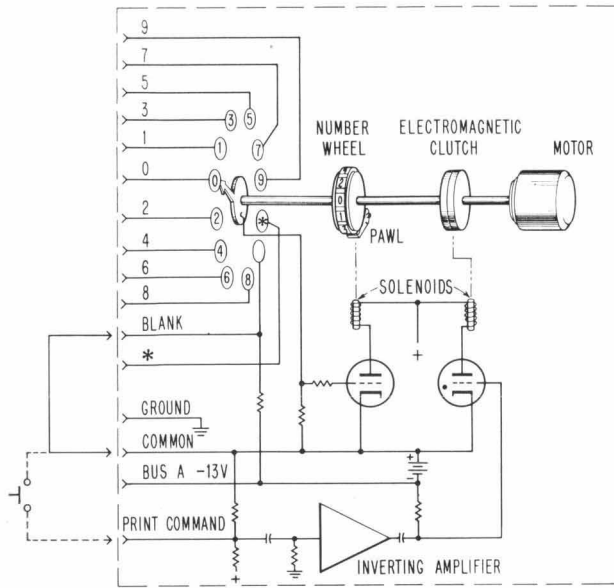

Fig. 3. Basic electro-mechanical arrangement of Model 561A printer with input connections indicated for one print wheel. All eleven wheels are mounted on same shaft. Print-outs can be initiated by negative transient applied to "Print Command" terminal or by external contact closure indicated by dashed lines at lower left.

poses. The requirement for entering information into the printer is merely that in each column the particular wire corresponding to a number to be printed be impressed with a 10-volt or more negative dc voltage. The printer is a parallel-input device so that signals must be impressed simultaneously in all columns to be printed.

The mechanical arrangement of the new printer is indicated in Fig. 3. The actual printing is done by a series of 11 identical number-faced wheels which are mounted on and friction-coupled to a common shaft. Each wheel face is divided into 12 segments and each wheel is provided with a stationary 12-segment commutator corresponding to the wheel face segments. When the wheel rotates, a brush synchronized with the wheel scans the commutator segments. Connections to the individual segments are brought out to externally-available terminals, while the brush connection is brought to a sensing circuit. The impedance looking into the commutators has been made high (1 megohm) to permit the instrument to operate from low-power sources such as diode matrices.

Operation of the mechanism occurs in the following manner. When a command signal is applied to the "Command" terminal (Fig. 3), it is amplified and used to fire a thyatron. Anode current from the thyatron then closes a solenoid and activates a clutch that couples the print wheel shaft to a

continuously-running

motor. The wheel shaft then begins to rotate and, owing to the friction coupling between the number wheels and the wheel shaft, the number wheels also begin to rotate. As the wheels rotate, each wheel brush scans the individual commutator segments until the segment is reached that contains the code voltage. This voltage is applied through the brush to a sensing tube grid, cutting off the tube and releasing the solenoid in its plate circuit. This action releases a pawl which drops against the number wheel, locking the proper number in a pre-determined position for printing.

This same action has also been occurring with the other 10 wheels on the shaft in accordance with the information entered on their commutators, so that by the time the shaft has turned nearly one rotation all of the wheels are locked in whatever position the voltages on the wheel commutators have dictated. At the end of the shaft rotation a print bar automatically presses the print paper and an inked ribbon against the number wheels, transferring the eleven sets of 10-wire code signals to printed form. The wheel-positioning cycle occurs in 160 milliseconds, while the printing cycle occurs in 40 milliseconds. The total cycle thus occurs in 200 milliseconds so that 5 print-outs per second can be obtained.

#### PRINT COMMAND

The printer is designed so that its scan-print cycle becomes initiated on command, thus enabling the printer to be controlled by the external system. The command can be an external negative signal of 15 volts

minimum amplitude or an external contact closure such as one of the contacts on a programmed stepping switch. Quite simple contact closures such as manually operated momentary-contact toggle switches can also be used. The contact closure should connect the "Print Command" terminal (Fig. 3) to the "Common" terminal.

#### EXTERNAL DISABLING RELAY

During the 160-millisecond period of the scan cycle, the information applied to the printer must remain fixed. Oftentimes, this requirement will be met naturally by the external equipment but in some cases a special relay included in the printer may be of convenience. The relay has a single-pole double-throw contact arrangement such that one contact opens and one closes when the print command signal is applied to the printer. This condition is maintained until completion of the scan cycle. External equipment can thus be prevented from changing information during this cycle by routing a suitable circuit through these contacts.

#### WHEEL SYMBOLS

Of the twelve positions on each type wheel, ten are occupied by numerals while the eleventh is provided with an asterisk (\*) as a general-purpose symbol. The asterisk can be used for indicating polarity or for other coding. Other symbols such as +, -,  $\Omega$ , letters of the alphabet, etc., can also be supplied.

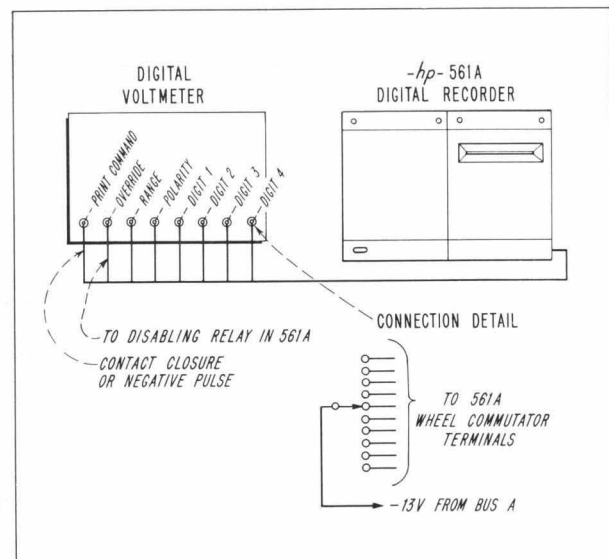

Fig. 4. Typical interconnection arrangement for using printer with digital voltmeter. Printer provides negative voltage source for feeding voltmeter contact closures.

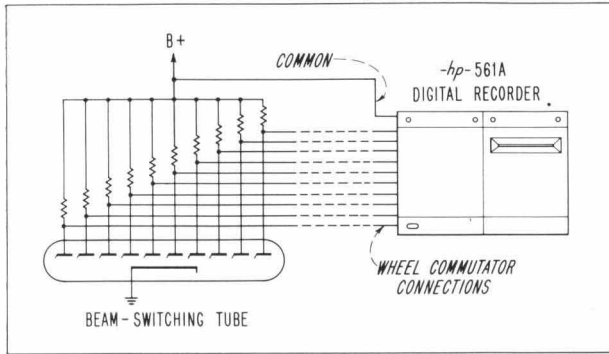

Fig. 5. Typical arrangement for feeding one column of printer from 10-element data device. Printer circuits are floating to permit operation from off-ground sources and have high input impedance so that source loading is small.

The twelfth position on each wheel is blank so that the wheel will not print if not used. All wheels have this position internally programmed in such a way that only the blank position can be obtained unless the wheel commutator terminals have external connections made to them.

#### VOLTMETER USE

Digital voltmeters that operate on stepping switch principles usually provide their output in the form of contact closures which are equivalent to single-pole 10-position switches. A typical arrangement for operating the printer\* with such a voltmeter is shown in Fig. 4. The contact closures corresponding to each digit of the voltmeter readout connect to the appropriate number wheel input connections on the printer. The printer provides a source of dc voltage from bus "A" which is connected to the switch rotors on the voltmeter. The voltmeter will then feed this dc back to the printer through the contact closures so that the printer receives a signal on the appropriate wire of the 10-line codes.

Each print-out is initiated either by a signal produced by the voltmeter or by a special contact closure provided in the voltmeter for the purpose. Where necessary to insure that the voltmeter holds its information for the duration of the 160-millisecond scan cycle, the contacts on the disabling relay in the printer can be used in an override circuit for the voltmeter.

The same general setup indicated in Fig. 4 can also be used to obtain print-outs from such devices as shaft encoders, stepping switches, relay matrices, mechanical counters with commutators, etc.

#### PRINT-OUTS

Fig. 2 (first page) demonstrates the result of a typical method of program-

ming the printer. The asterisk and blank positions on one wheel can be programmed to indicate polarity by making the asterisk equal to + or - as desired. The reading can be programmed to the next wheels, while range information can be printed in a final column which is isolated from the voltage reading by the space of an unprogrammed column. Multiplexing arrangements can also be used to obtain print-outs of check-out systems.

#### OTHER SYSTEMS

Fig. 5 indicates a typical instance of how the printer can be operated with other devices of the type that provides an output in 10-wire code form. The illustration indicates the case of a beam-switching tube in which a readout occurs when the formed electron beam is directed to a particular target electrode out of the group of 10 electrodes in the tube. The voltage at that target will then be lower than at the other targets and this reduced voltage constitutes the signal that operates the printer. Similar source arrangements are often used in 10-lamp or 10-ele-

ment remote readout units, converters, counter type voltmeters, gas-discharge indicator tubes, diode matrices, etc. The printer circuits are electrically floating and can be operated up to  $\pm 300$  volts from chassis to permit operation with devices such as beam-switching tubes where the connections may be at or near the tube B supply.

Print command and override arrangements can usually be obtained with these systems in the same general manner indicated for digital voltmeters.

#### MULTIPLE CHANNEL PRINT-OUTS

The 11-column printing system permits readouts to be obtained not only where large numbers are involved but also where two or three channels of smaller numbers are of interest. Voltages at two or three different points in a system, for example, can be printed as can the output of testing systems that measure several variables.

Multi-channel printing does not require that each external channel make its measurement simultaneously, but it does require that the information from each channel be available to the printer at the moment that the print command signal is applied and for 160 milliseconds thereafter to enable the type wheels to become positioned.

#### LINE SPACING

The printer includes a control for adjusting the line spacing of printing for either single or double spacing (6 or 3 lines per inch). Zero spacing can also be selected and is convenient when making initial equipment setup adjustments.

### SEPARATE PRINTER MECHANISM

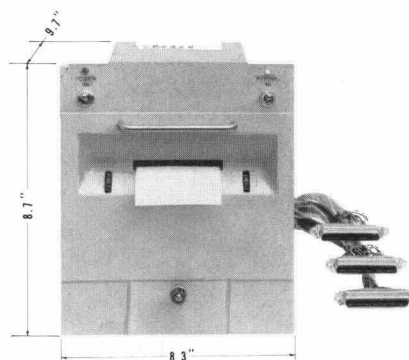

For convenience where it is desirable to incorporate the printer into other equipment, the printer mechanism is available without associated electronic circuitry and cabinet. The mechanism (see illustration) consists of the complete printing assembly, motor, paper mechanism, all necessary solenoids, etc.

To operate the mechanism, the external equipment must provide the power for the wheel and clutch solenoids as well as sensing and switching circuitry for applying the power. The wheel solenoids can be provided in various ratings to suit them to tube or transistor sources.

The mechanism is also available for operation with staircase coding such as is used in the -hp- Model 560A Digital Recorder. See specifications on back page.

\*Isolated single-pole 10-position output systems can also be used to operate the -hp- Model 560A Digital Recorder by connecting the isolated switch contacts into a suitable staircase.



## PRINTER

(Continued from page 3)

### PAPER TAPE

The printer uses standard 3-inch adding machine tape which is available either in standard roll form or in an accordion-folded style. The latter has been found to be more often preferred and a supply of this style is provided. A drawer at the front of the instrument can be extended to receive the tape as it is printed.

—Ed A. Hilton

### SPECIFICATIONS

—hp—

#### MODEL 561A DIGITAL RECORDER

Column capacity: 11 columns (11 digits per line).

Print rate: 5 lines per second or 3300 characters per minute maximum.

Number wheels: 12 positions having numerals 0 through 9, an asterisk, and a blank. Other symbols are available on special order.

Information entry: Through individual wires, one for each position of each wheel, brought to female connector.

Driving source: Stepping Switches, Relays, Beam Switching Tubes, contact closure or —10 to —100 volts connected to appropriate number wire. Operates from 10-wire coded systems.

Input impedance: 1 megohm.

Print command: An external contact closure, or a negative pulse 15 volts peak or more, 10 microsecond minimum width. Manually controllable by a momentary contact toggle switch. Print commands during scan and print action have no effect.

Paper required: Standard 3 inch roll or folded paper tape.

Line spacing: Single or Double, automatic paper advance.

Power: 60 cps, 115  $\pm$ 10V or 230  $\pm$ 20V as specified. 50 cps operation available on special order.

Dimensions: Cabinet Mount: 20 1/2" wide, 12 1/2" high, 18 1/2" deep. Rack Mount: 19" wide, 10" high, 16 1/2" deep behind panel. Required rack depth is 19 inches.

Weight: Cabinet Mount: Net 35 lbs.; Rack Mount: Net 30 lbs.

Accessories available: 1052-24 Folded Paper Tape \$1.00 packet, \$20.00/24 packet carton.

Price: —hp— Model 561A Digital Recorder, in quantities of 1 to 9, Cabinet Mount: \$975.00, Rack Mount: \$960.00  
in quantities of 10 to 24, Cabinet Mount: \$925.00, Rack Mount: \$910.00.

### PRINTER MECHANISMS

10-wire code mechanism from —hp— 561A: \$600.00; Staircase code mechanism from —hp— 560A: \$600.00.

Quantity prices on request.

Prices f.o.b. Palo Alto, California

Data subject to change without notice

## A CURRENT-LIMITING REGULATED POWER SUPPLY FOR TRANSISTOR WORK

A new regulated power supply has been designed for powering low-voltage circuits such as those using transistors. For transistor work the supply has been designed so that its output current cannot exceed any one of four selectable values, even under shorted-terminal conditions, thus giving considerable protection against accidental overload of valuable components under test. The supply itself is also fully transistorized, and this current-limiting feature fully protects the internal circuits as well.

The supply provides voltages which are adjustable from 0 to 30 vdc at rated currents up to 150 ma. Either voltage or current can be monitored by a direct-reading panel meter which is arranged to have full-scale values of 10 and 30 volts and 10, 30, 100, and 300 ma. For circuit protection a panel switch sets the maximum available current at 25, 50, 100, or 225 ma. The output terminals are floating and either side can be grounded as a convenience in using various transistor configurations. The output can also be connected in series with other supplies up to 400 volts from ground potential.

Electrical performance of the supply is nicely suited to transistor work. Regulation at any voltage setting is within 0.3% or 30 mv for a current change from no current to full rated current (150 ma). Line voltage changes of  $\pm$ 10% from 115 volts cause less than 0.3% or 15 mv change in output voltage. Ripple and noise are at a very low value—less than 150 microvolts rms—so that the supply is useful with low-level circuitry.

Typical output impedance of the supply is indicated in Fig. 2. The impedance appears as less than a 0.2-ohm resistance in series with something less than 30 microhenries. At high frequencies the source impedance becomes that of a 0.1-mf capacitor connected internally across the output terminals. The

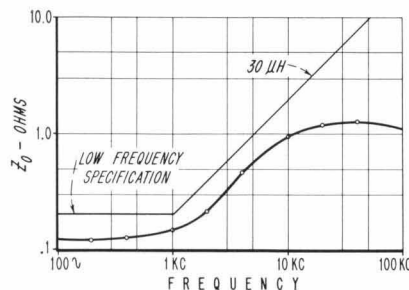

Fig. 2. Typical source impedance of Model 721A power supply.



Fig. 1. —hp— Model 721A power supply provides 0 to 30 vdc at currents up to 150 ma. Maximum current available can be set by panel switch to minimize accidental overloading of sensitive external circuits.

output resistance shown in Fig. 2 assumes that the meter is switched to the voltage position, as do the regulation figures cited earlier.

Physical size is worthy of mention since the supply requires less bench area (7" wide x 5.2" deep) than a conventional textbook and is but 4.3" high. Similarly, weight is only 4 pounds. Rubber feet are provided on bottom and back sides to enable it to be used with the panel either vertically or horizontally positioned. Units can also be stacked if desired.

—Donald F. Schulz

### SPECIFICATIONS

—hp—

#### MODEL 721A POWER SUPPLY

Regulated output voltage: 0 to 30 volts dc, continuously variable.

Maximum load current: 150 ma for voltage regulation; maximum available current, approx. 225 ma.

Load regulation: With the meter monitoring voltage, the change in output voltage from no load to full load is less than 0.3% or 30 mv whichever is greater.

Line regulation: Change in output voltage for a change from nominal line voltage of  $\pm$ 10% is less than  $\pm$ 0.3% or  $\pm$ 15mv whichever is greater.

Ripple and noise: Less than 150 $\mu$ v rms.

Output impedance: Less than 0.2 ohm in series with less than 30 $\mu$ h.

Meter ranges: Full scale indications of: 10 ma, 30 ma, 100 ma, 300 ma, 10 v, and 30 v.

Overload protection: Maximum current selected by switch in four steps, 25 ma, 50 ma, 100 ma, 225 ma.

Output terminals: Three banana jacks spaced 3/4" apart. Positive and negative terminals are isolated from chassis. A maximum of 400 volts may be connected between ground and either output terminal.

Power: 115/230 volts  $\pm$ 10%, 50 to 60 cps, 16 watts.

Weight: Net 4 lbs., Shipping 7 lbs.

Dimensions: 7" wide, 4 3/8" high, 5 1/4" deep.  
Price: —hp— Model 721A Power Supply \$145.00, f.o.b. Palo Alto, California.

Data subject to change without notice.